

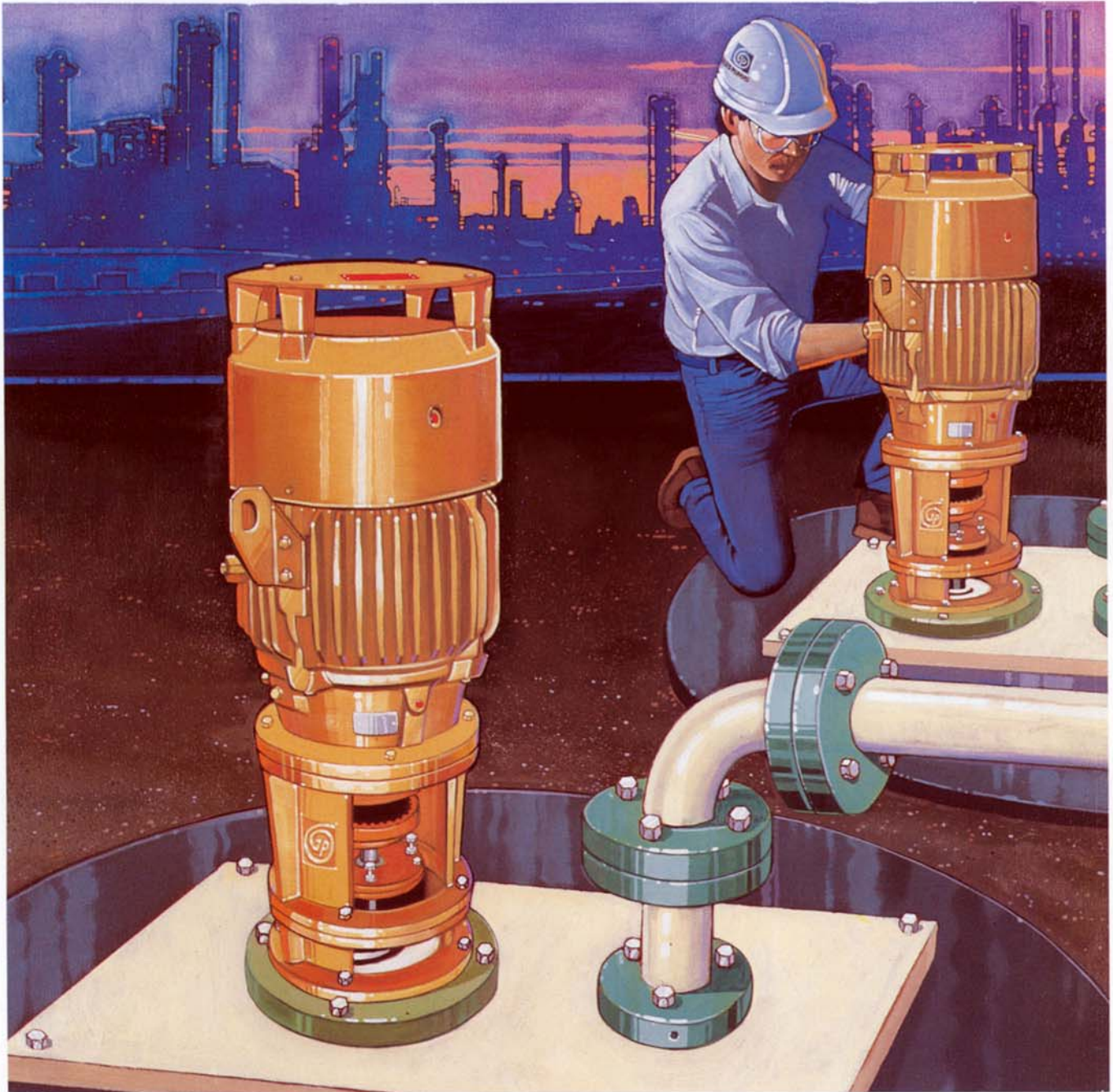

GOULDS PUMPS

Goulds Model NM 3171 Non-Metallic Vertical Process Pumps



ITT



Goulds Model NM 3171

Non-Metallic Vertical Sump and Process Pumps Designed for Severe Corrosive Services

- Capacities to 1250 GPM (284 m³/h)
- Heads to 300 feet (92 m)
- Temperatures to 200° F (79° C)
- Pit Depths to 16 feet (5 m)

Design Features

- Cost Effective Alternative to High Alloys
- Corrosion Resistant RULON® Column Bearings
- Casing and Impeller Molded with High Strength, Corrosion Resistant GMP-2000*
- Casing and Impeller Interchangeable with Goulds Model NM 3196
- Rugged Double Row Thrust Bearing
- Thrust Bearing Sealed Against External Contamination
- Heavy Duty One-Piece Solid Shaft
- External Impeller Adjustment

Services

Chemical/Petrochemical Waste acid, Hydrochloric acid, Sodium hydroxide; Ferric chloride, Sulfuric acid, Spinfoinish wastes

Utility Coal pile runoff, Sea water, Demineralized water

Metal Finishing Spent pickling solutions, Electroplating rinses, Nickel plating baths

General Industrial process; Deionized water, Pollution control, Sump services

©RULON is a registered trademark of Dixon Industries Corp.
* Proprietary molding process/material GMP-2000



Goulds Model NM 3171 Non-Metallic Vertical Process Pumps

Design Features for Severe Corrosive Services

STANDARD NORMAL THRUST MOTORS
P-base, C-Face, I.E.C.

NON-SPACER FLEXIBLE COUPLING

SEALED, SELF-CONTAINED THRUST BEARING ASSEMBLY
Sealed at both ends to protect bearing from corrosive vapors.

DOUBLE ROW THRUST BEARING
Greased for life—standard.

HEAVY DUTY FRP MOUNTING PLATE

VAPOR SEAL CONSTRUCTION
Teflon® U-cup seal assures product vapors are contained in column.

OVERSIZED SHAFT
Available in 316 stainless steel, Alloy 20, Hastelloy B & C, Titanium.

HIGH STRENGTH FRP COLUMN PIPE

CORROSION RESISTANT RULON® BEARINGS
Designed specifically for non-metallic pump services.

HIGH PERFORMANCE VOLUTE DESIGN
High efficiency, true volute design achieved by exclusive Greg Molding Process.

POSITIVE LIQUID SEALING AT IMPELLER
Corrosion resistant Viton O-ring protects threaded area against corrosion.

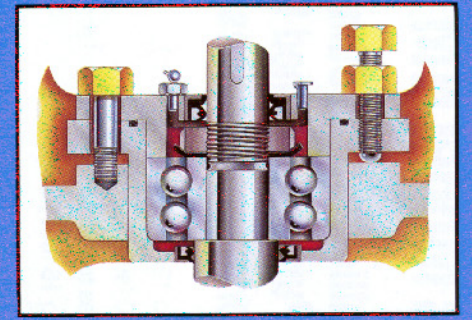

REGREASABLE OPTION

EXTERNAL IMPELLER ADJUSTMENT
Original high efficiency maintained by simple adjustment.

NO ALIGNMENT REQUIRED
Precision rabbeted fits assure shaft alignment.

150 LB. FRP DISCHARGE FLANGE

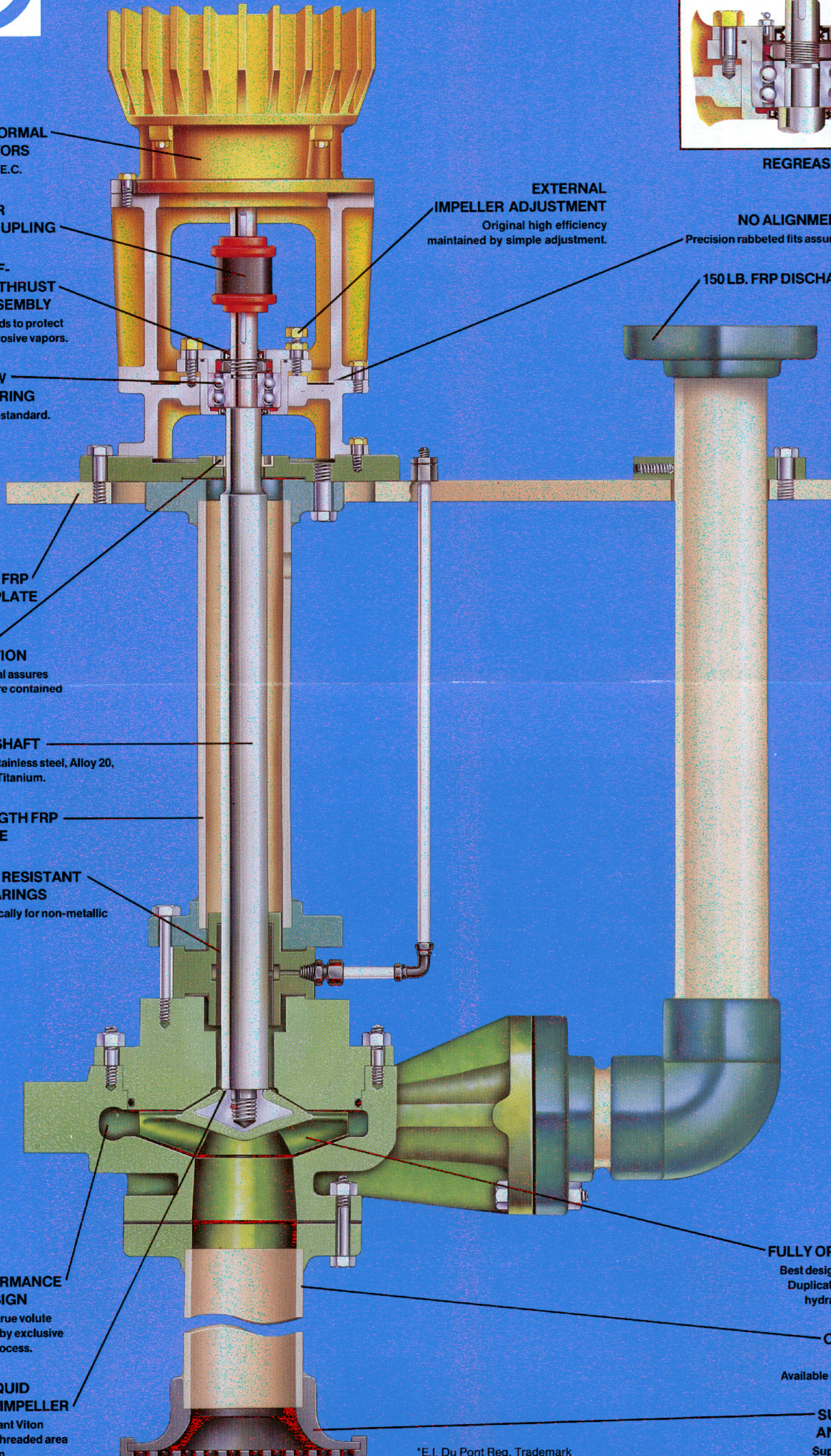

FULLY OPEN IMPELLER
Best design for CPI services. Duplicates Model NM 3196 hydraulic performance.

OPTIONAL FRP TAIL PIPE
Available in lengths to 6 feet.

SUCTION BELL AND STRAINER
Supplied as standard.

Designed for Reliability

Thrust Bearing Design

Mechanical Reliability Oversized double row thrust bearing accommodates entire range of NM 3171 sizes. Bearing is greased-for-life as standard for minimum maintenance.

Protected from Contamination Three-way bearing protection:

- Double lip shaft seals installed top and bottom.
- O-ring seal between bearing housing and end cover.
- Teflon U-cup vapor seal installed in shaft column.

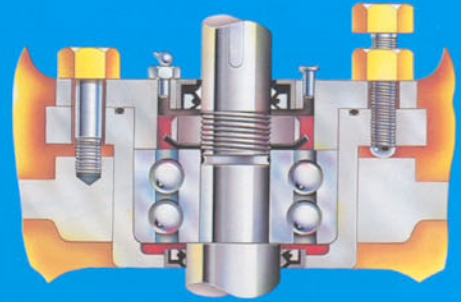

Column Bearing Design

Superior column bearing performance is assured by a special RULON® bearing ... a polymetric fluoropolymer material designed specially for use with high alloy shafting. RULON® provides significant advantages:

- Extremely low coefficient of friction.
- Chemically inert.
- Low wear rate.
- Minimum lubrication requirements.
- Ideal for non-metallic pumps and severe corrosive services.

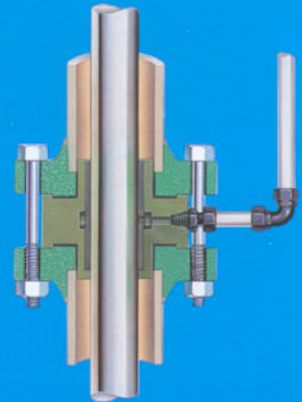

Corrosion Resistant Construction

GMP-2000 Casing and Impeller

The NM 3171 casing and impeller are molded with high strength corrosion resistant GMP-2000 using the proprietary Greg Molding Process.

Fibercast Piping

Fibercast Piping Column and discharge pipe are fabricated with quality Fibercast®.



* Fibercast is a registered trademark of Fibercast Company.

Finite Element Impeller Analysis

Recognizing that the impeller must perform to high standards of mechanical reliability, Goulds developed a finite element stress analysis to explore design options. The result is an impeller that assures continuous trouble-free operation and superior hydraulic performance.

Goulds NM 3171 impeller was designed utilizing the most sophisticated tools available: finite element stress analysis combined with stress measurements using Stress Kote and stress gage techniques.

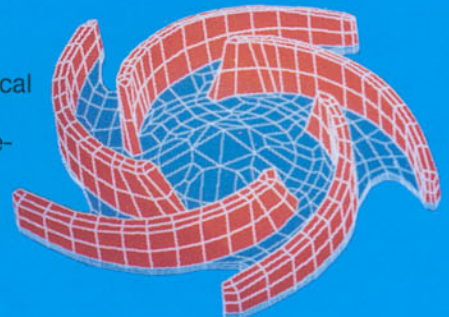

Hydraulic Coverage 50 & 60 Hz

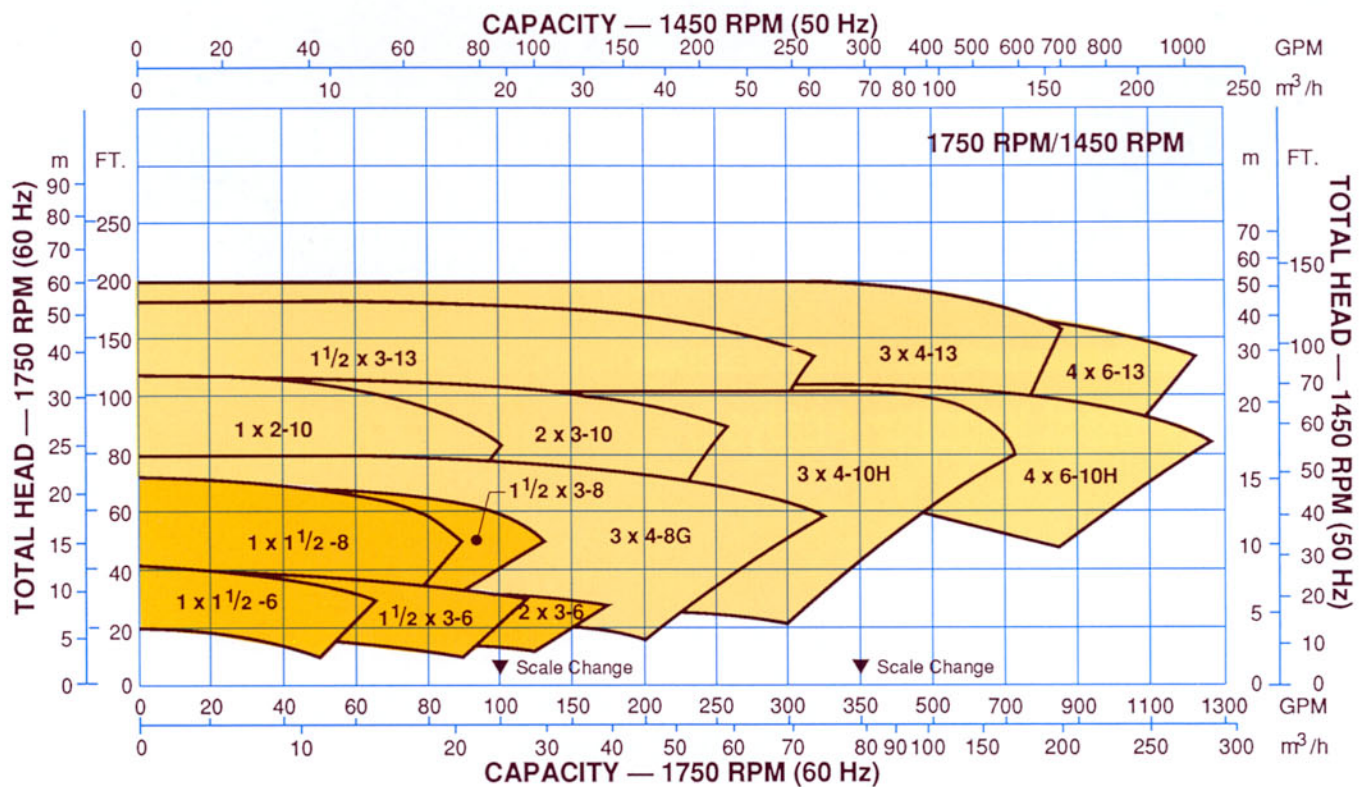
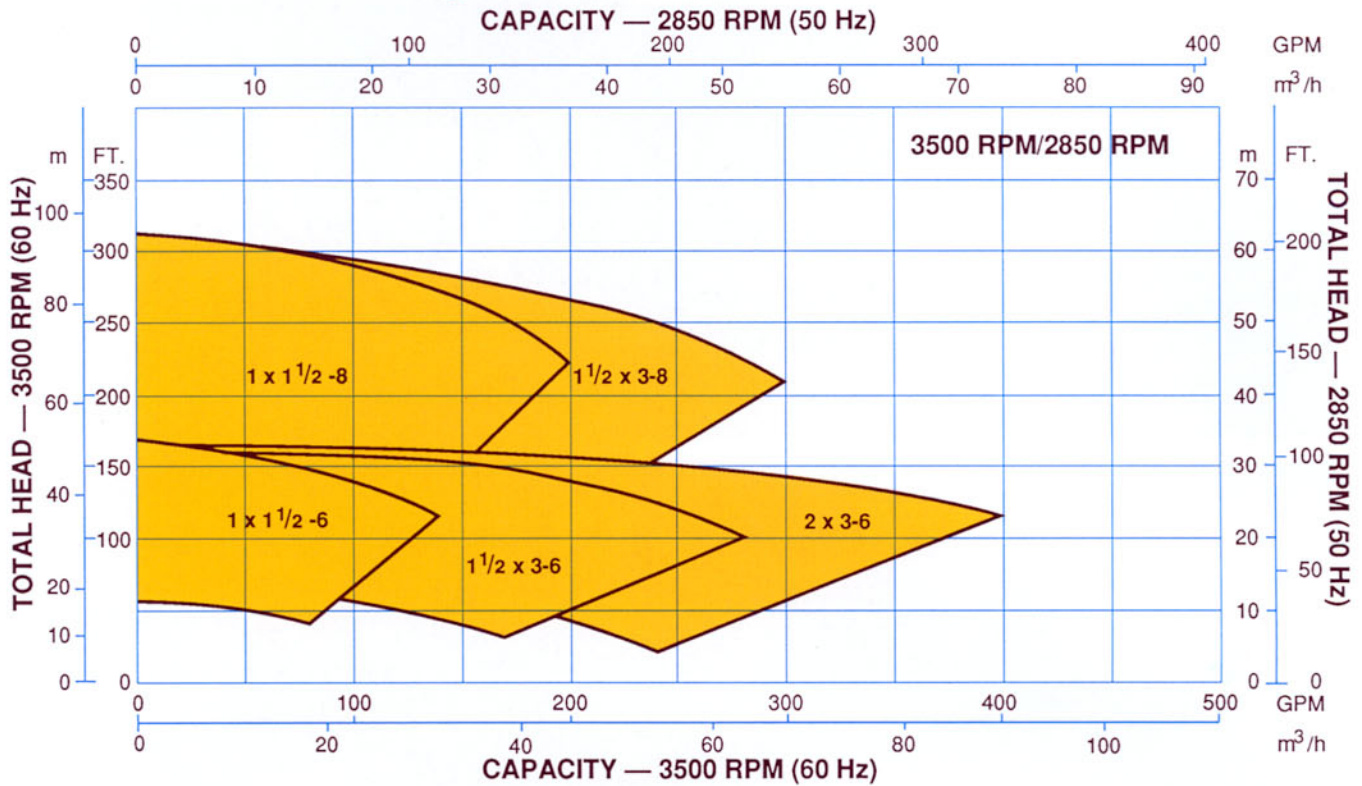

Hydraulic Coverage 50 & 60 Hz

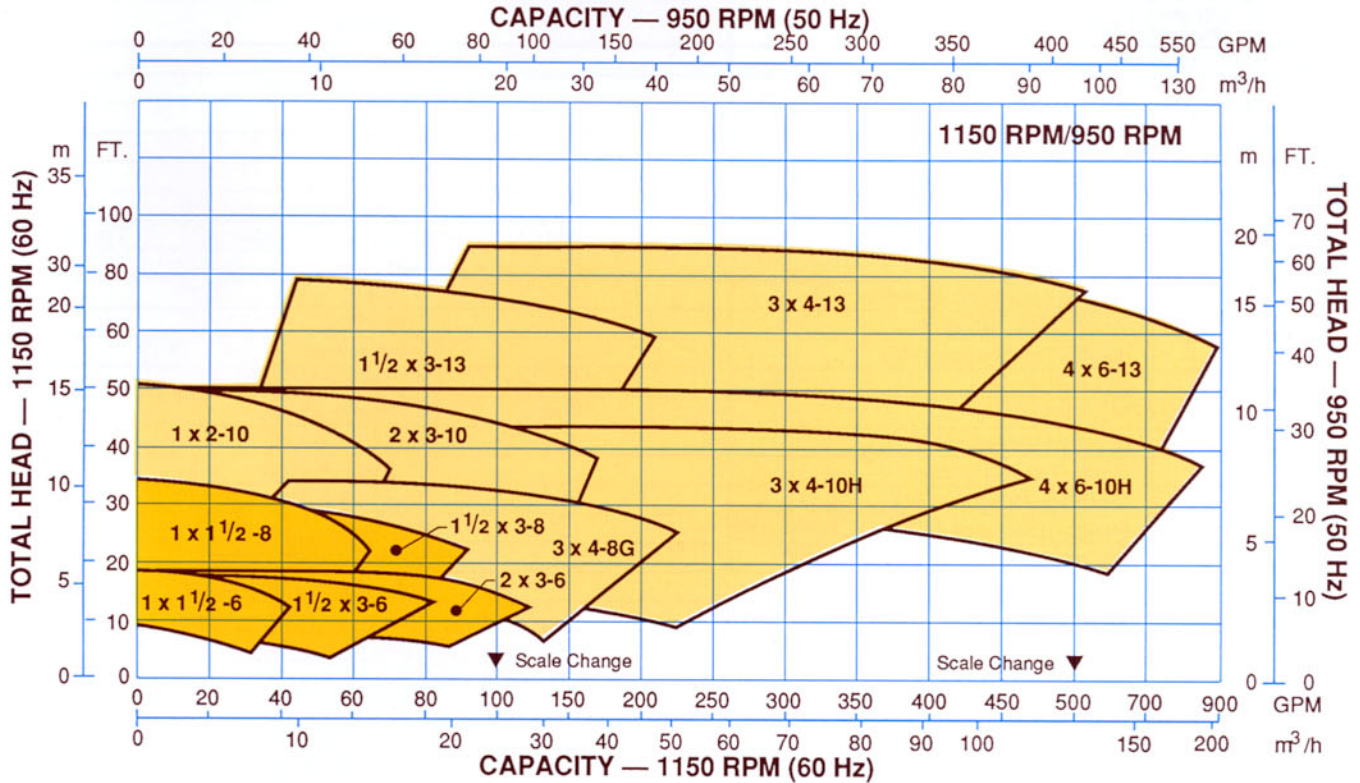

Construction Details

Group ▶		ST					MT								
		Pump Size ▶		1x1 1/2-6	1 1/2x3-6	2x3-6	1x1 1/2-8	1 1/2x3-8	3x4-8G	1x2-10	2x3-10	3x4-10H	4x6-10H	1 1/2x3-13	3x4-13
Pump	Weight—3 Ft. Depth Less Motor—Lb. (kg)	125 (57)		135 (61)	140 (64)	155 (70)	160 (73)	170 (77)	200 (91)	210 (95)					
	Weight—Add For Each 6 In. Length—Lb. (kg)	15 (7)													
Casing	Maximum Diameter Solids—In. (mm)	11/32 (8.7)	7/16 (11.1)	3/8 (9.5)	11/32 (8.7)	7/16 (11.1)	11/16 (17.5)	7/32 (5.6)	3/8 (9.5)	5/8 (15.9)	1 (25.4)	7/32 (5.6)	5/8 (15.9)	1 (25.4)	
	Maximum Discharge—Head—Ft. (m)	170 (52)			290 (88)		76 (23)	122 (37)		180 (55)					
Shaft	Diameter At Coupling End—In. (mm)	1 (25.4)													
	Diameter At Steady Bearings—In. (mm)	1 3/8 (34.9)					1 1/4 (44.4)								
	Diameter At Impeller—In. (mm)	3/4 (19.1)					1 (25.4)								
	First Critical Speed (minimum)	4500 RPM													
Bearings	Thrust Bearing	5306													
	Steady Bearing—Sleeve Type—In. (mm)	1 1/8 I.D.x4 L. (34.9 I.D.x101.6 L.)					1 1/4 I.D.x4 L. (44.4 I.D.x101.6 L.)								
	Maximum Spacing—Center-to-Center—In. (mm)	32 (813)													
Maximum Liquid Temperature		200° F (79° C)													

Parts List and Materials of Construction

Part No.	Qty per Pump	Part Name	Material				
100	1	Casing	GMP-2000				
101	1	Impeller with Insert	GMP-2000/Hastelloy C				
108	1	Adapter	Cast Iron				
109	1	Bearing End Cover	Cast Iron				
112	1	Ball Bearing	Steel				
113	1	Grease Relief Fitting (Optional)	Steel				
122	1	Shaft	316 SS	Alloy 20	Hastelloy B	Hastelloy C	Titanium
134	1	Bearing Housing	Cast Iron				
136	1	Bearing Locknut/Lockwasher	Steel				
180	1	Pump Cover	Polyester				
181	1	Suction Tail Pipe Assembly	Polyester				
189	1	Mounting Plate	Polyester				
190	1-4	Flush Tubing	Polypropylene				
192	1-4	Column Pipe Assembly	Vinyl Ester				
193A	1	Grease Fitting (Optional)	Steel				
195	1	Discharge Pipe Assembly	Vinyl Ester				
195C	1	Flange—Discharge Pipe	Vinyl Ester				
213	1-4	Column Bearing Assembly	Polyester/Rulon®				
215	1	Protector Plate	Polyester				
215A	1	Vapor Seal	Teflon				
240	1	Motor Support	Cast Iron				
242	1	Pipe Collar	Polyester				
332	1	Lip Seal—Upper	Steel/Buna				
333A	1	Lip Seal—Lower	Steel/Buna				
351A	1	Gasket—Casing/Discharge Pipe Assembly	Non-Asbestos				
356A	4-16	Stud/Nut—Casing/Pump Cover	316 SS	Alloy 20	Hastelloy B	Hastelloy C	Titanium
360Y	1	Gasket—Casing/Tail Pipe Assembly	Non-Asbestos				
371H	4-8	H Cap Screw—Casing/Discharge Pipe Assembly	316 SS	Alloy 20	Hastelloy B	Hastelloy C	Titanium
371W	4	H Cap Screw—Column Pipe Assembly/Pump Cover	316 SS	Alloy 20	Hastelloy B	Hastelloy C	Titanium
371Z	4	H Cap Screw—Column Pipe Assembly/Protector Plate	316 SS	Alloy 20	Hastelloy B	Hastelloy C	Titanium
372A	4-8	H Cap Screw—Casing/Suction Tail Pipe Assembly	316 SS	Alloy 20	Hastelloy B	Hastelloy C	Titanium
372B	4-12	H Cap Screw—Column/Column Tail	316 SS	Alloy 20	Hastelloy B	Hastelloy C	Titanium
412A	1	O-Ring—Impeller	Acid-Resistant Viton				
412Z	1	O-Ring—Pump Cover	Acid-Resistant Viton				
445A	1	Pin—Anti-Rotation	Nylon				
496	1	O-Ring—Bearing Housing	Buna				

Note: All hardware above mounting plate is 304 stainless steel.

Horizontal Non-Metallic Process Pumps For Application Flexibility

Goulds Model NM 3196 is a horizontal version of the NM 3171. Liquid end parts are made of the same material—high strength, corrosion resistant GMP-2000. Available in thirteen sizes, the NM 3196 conforms to dimensional requirements of ANSI B73.1 and includes ANSI features such as foot-mounted, centerline discharge casings and back pull-out design. A corrosion resistant FRP baseplate is standard.

For complete details, ask for Goulds Bulletin 725.6.



Model NM 3196 ST

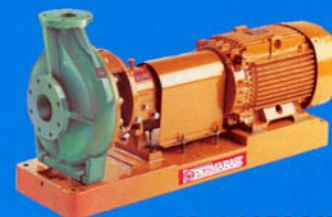

Model NM 3196 MT

Sectional View Model NM 3171

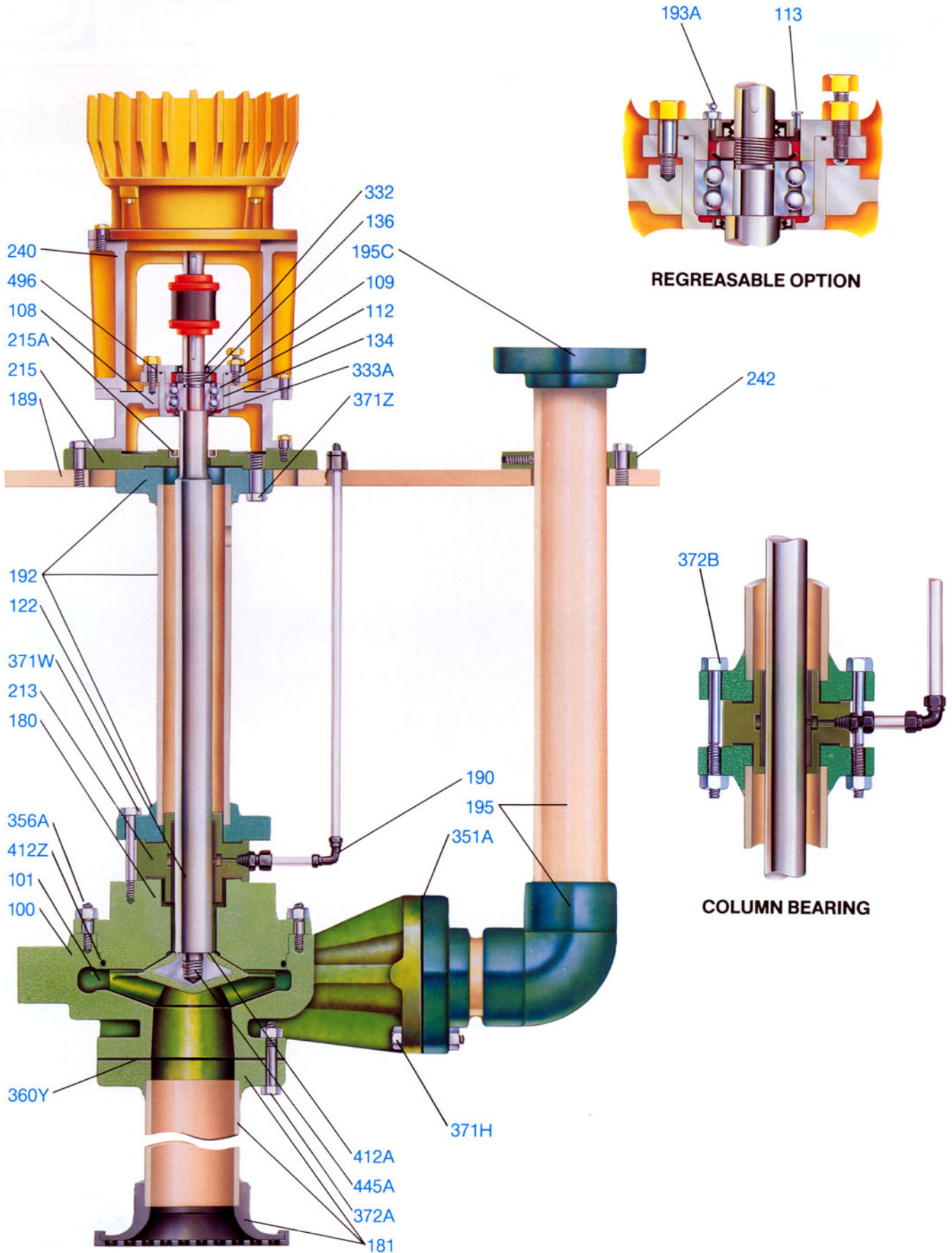

Dimensions Model NM 3171

All dimensions in inches (mm). Not to be used for construction.

DIMENSIONS—PUMP SETTING

Set No.	Pit Depth J in Ft(m)	No. of Steady Bearings	K	R
01	3.00 (.914)	1	28.50 (723.9)	7.50 (190.5)
02	3.50 (1.067)		34.50 (876.3)	
03	4.00 (1.219)		40.50 (1028.7)	
04	4.50 (1.372)		46.50 (1181.1)	
05	5.00 (1.524)	2	54.50 (1384.3)	5.50 (139.7)
06	5.50 (1.676)		60.50 (1536.7)	
07	6.00 (1.829)		66.50 (1689.1)	
08	6.50 (1.981)		72.50 (1841.5)	
09	7.00 (2.134)	3	78.50 (1993.9)	6.50 (165.1)
10	7.50 (2.286)		83.50 (2120.9)	
11	8.00 (2.438)		89.50 (2273.3)	
12	8.50 (2.591)		95.50 (2425.7)	
13	9.00 (2.743)	4	101.50 (2578.1)	7.50 (190.5)
14	9.50 (2.896)		107.50 (2730.5)	
15	10.00 (3.048)		112.50 (2857.5)	

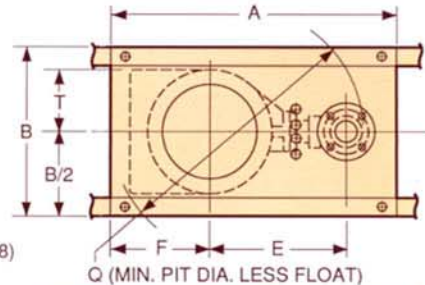
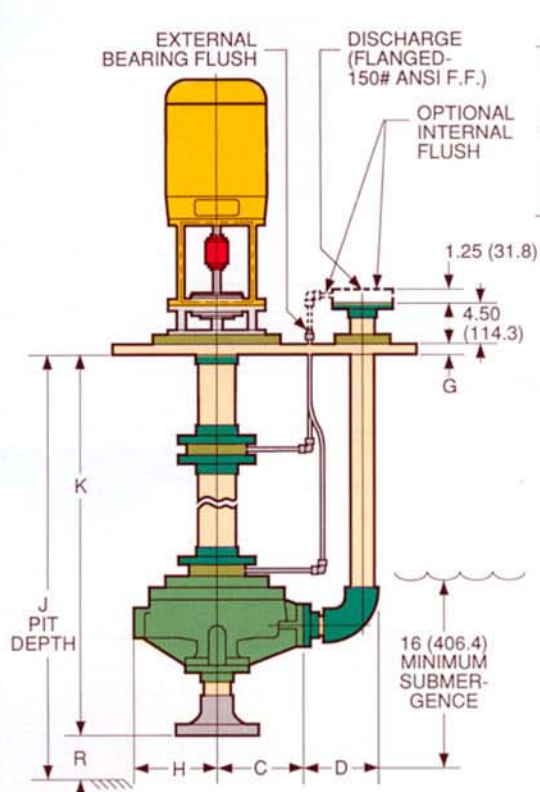

OPTIONAL SUCTION TAIL PIPE

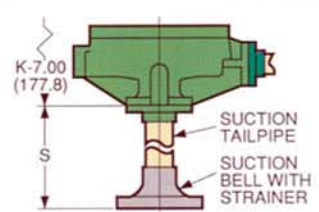

S	
12.00 (304.8)	48.00 (1219.2)
18.00 (457.2)	54.00 (1371.6)
24.00 (609.6)	60.00 (1524.0)
30.00 (762.0)	66.00 (1676.4)
36.00 (914.4)	72.00 (1828.8)
42.00 (1066.8)	

DIMENSIONS DETERMINED BY PUMP

Grp.	Size	Disch.	A	B	C	D	E	F	G	H	T	Weight* Lbs/(kg)	Q	
ST	1x1½-6	2	24.00 (609.6)	15.00 (381)	6.50 (165.1)	8.00 (203.2)	12.88 (327.2)	7.25 (184.2)	.75 (19.1)	5.25 (133.4)	4.50 (114.3)	125 (57)	22.00 (558.8)	
	1½x3-6	2									4.88 (123.9)			
	2x3-6	2									4.88 (123.9)			
	1x1½-8	2		18.00 (457.2)							5.50 (139.7)			135 (61)
	1½x3-8	2		5.50 (139.7)										
MT	3x4-8G	3	36.00 (914.4)	18.00 (457.2)	11.00 (279.4)	9.12 (231.6)	18.00 (457.2)	11.75 (298.5)	1.00 (25.4)	8.25 (209.6)	6.88 (174.7)	140 (64)	31.00 (787.4)	
	1x2-10	2			8.50 (215.9)	11.12 (282.4)					6.75 (171.5)	155 (70)		
	2x3-10	2			9.50 (241.3)	10.12 (257.1)					7.00 (177.8)	155 (70)		
	3x4-10H	3	36.00 (914.4)	30.00 (762)	12.50 (317.5)	9.12 (231.6)	19.50 (495.3)	12.00 (304.8)	10.00 (254)	7.62 (193.5)	175 (79)	35.00 (889)		
	1½x3-13	2			10.50 (266.7)	11.12 (282.4)				8.62 (218.9)	200 (91)	34.00 (863.6)		
	3x4-13	3	40.00 (1016)	30.00 (762)	12.50 (317.5)	9.12 (231.6)	21.12 (536.4)	13.00 (330.2)	10.00 (254)	9.62 (244.3)	200 (91)	36.00 (914.4)		
	4x6-10H	4			13.50 (342.9)	10.25 (260.4)				8.00 (203.2)	155 (70)			
	4x6-13	4			10.38 (263.7)	250 (113)								

* Weight shown is for 36 in. pit depth. Weight increases by 30 lb. (13.6 kg) for each additional 1 foot increment. Weights are approximate.

Visit our website at www.gouldspumps.com

