

# GOULDS PUMPS

## MODEL HSD

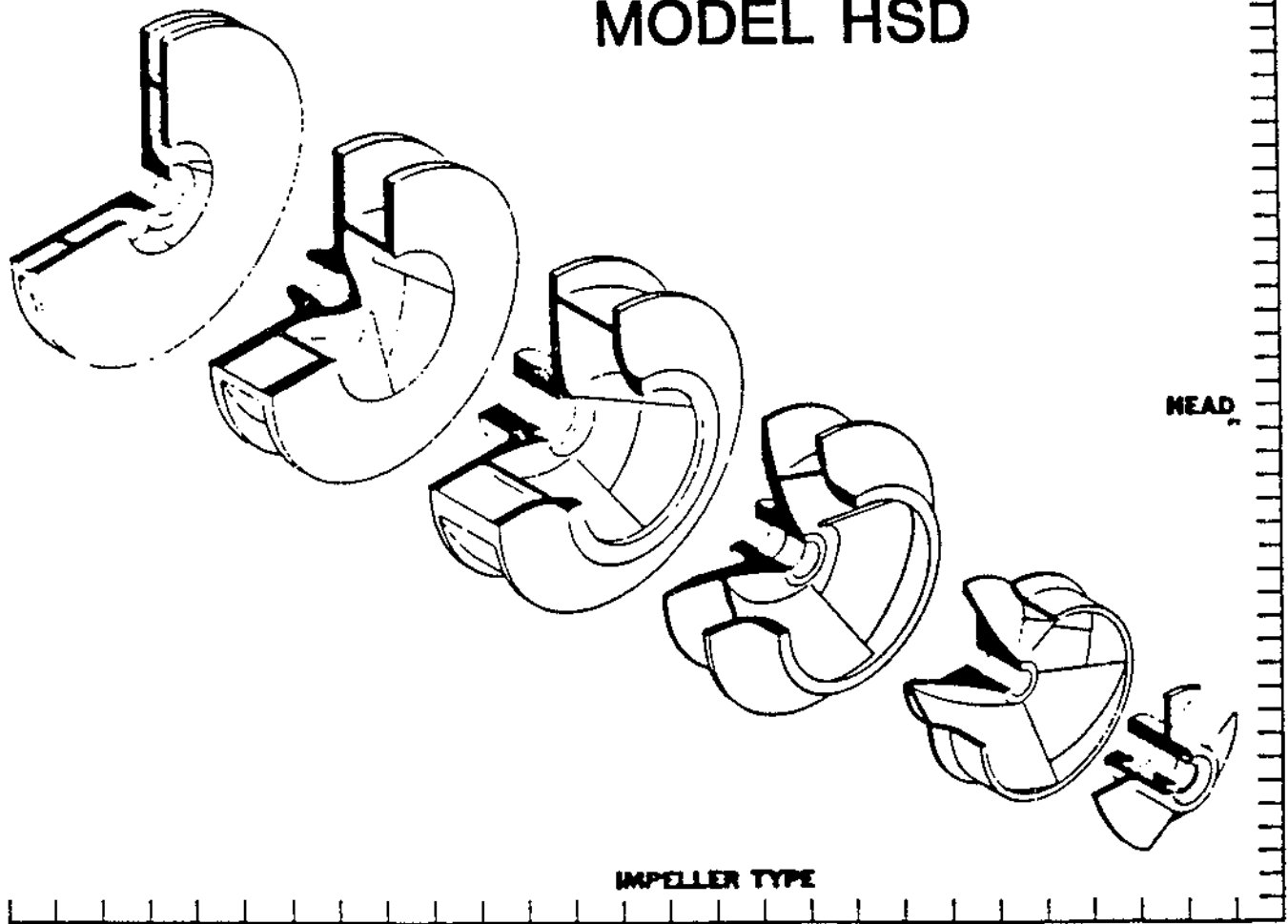

 GOULDS PUMPS, INC.  
SLURRY PUMP DIVISION

INST NO:  
2382

## IMPORTANT SAFETY NOTICE

*To: Our Valued Customers*

User safety is a major focus in the design of our products. Following the precautions outlined in this manual will minimize your risk of injury.

ITT Goulds pumps will provide safe, trouble-free service when properly installed, maintained, and operated.

Safe installation, operation, and maintenance of ITT Goulds Pumps equipment are an essential end user responsibility. This *Pump Safety Manual* identifies specific safety risks that must be considered at all times during product life. Understanding and adhering to these safety warnings is mandatory to ensure personnel, property, and/or the environment will not be harmed. Adherence to these warnings alone, however, is not sufficient — it is anticipated that the end user will also comply with industry and corporate safety standards. Identifying and eliminating unsafe installation, operating and maintenance practices is the responsibility of all individuals involved in the installation, operation, and maintenance of industrial equipment.

Please take the time to review and understand the safe installation, operation, and maintenance guidelines outlined in this Pump Safety Manual and the Instruction, Operation, and Maintenance (IOM) manual. Current manuals are available at [www.gouldspumps.com/literature\\_ioms.html](http://www.gouldspumps.com/literature_ioms.html) or by contacting your nearest Goulds Pumps sales representative.

**These manuals must be read and understood before installation and start-up.**

For additional information, contact your nearest Goulds Pumps sales representative or visit our Web site at [www.gouldspumps.com](http://www.gouldspumps.com).

# SAFETY WARNINGS

Specific to pumping equipment, significant risks bear reinforcement above and beyond normal safety precautions.

---

 **WARNING**

---

A pump is a pressure vessel with rotating parts that can be hazardous. Any pressure vessel can explode, rupture, or discharge its contents if sufficiently over pressurized causing death, personal injury, property damage, and/or damage to the environment. All necessary measures must be taken to ensure over pressurization does not occur.

---

 **WARNING**

---

Operation of any pumping system with a blocked suction and discharge must be avoided in all cases. Operation, even for a brief period under these conditions, can cause superheating of enclosed pumpage and result in a violent explosion. All necessary measures must be taken by the end user to ensure this condition is avoided.

---

 **WARNING**

---

The pump may handle hazardous and/or toxic fluids. Care must be taken to identify the contents of the pump and eliminate the possibility of exposure, particularly if hazardous and/or toxic. Potential hazards include, but are not limited to, high temperature, flammable, acidic, caustic, explosive, and other risks.

---

 **WARNING**

---

Pumping equipment Instruction, Operation, and Maintenance manuals clearly identify accepted methods for disassembling pumping units. These methods must be adhered to. Specifically, applying heat to impellers and/or impeller retaining devices to aid in their removal is strictly forbidden. Trapped liquid can rapidly expand and result in a violent explosion and injury.

ITT Goulds Pumps will not accept responsibility for physical injury, damage, or delays caused by a failure to observe the instructions for installation, operation, and maintenance contained in this Pump Safety Manual or the current IOM available at [www.gouldspumps.com/literature](http://www.gouldspumps.com/literature).

# SAFETY

## DEFINITIONS

Throughout this manual the words **WARNING**, **CAUTION**, **ELECTRICAL**, and **ATEX** are used to indicate where special operator attention is required.

**Observe all Cautions and Warnings highlighted in this Pump Safety Manual and the IOM provided with your equipment.**



### **WARNING**

Indicates a hazardous situation which, if not avoided, could result in death or serious injury.

**Example:** Pump shall never be operated without coupling guard installed correctly.

---



### **CAUTION**

Indicates a hazardous situation which, if not avoided, could result in minor or moderate injury.

**Example:** Throttling flow from the suction side may cause cavitation and pump damage.

---



### **ELECTRICAL HAZARD**

Indicates the possibility of electrical risks if directions are not followed.

**Example:** Lock out driver power to prevent electric shock, accidental start-up, and physical injury.

---



When installed in potentially explosive atmospheres, the instructions that follow the Ex symbol must be followed. Personal injury and/or equipment damage may occur if these instructions are not followed. If there is any question regarding these requirements or if the equipment is to be modified, please contact an ITT Goulds Pumps representative before proceeding.







**Example:**  Improper impeller adjustment could cause contact between the rotating and stationary parts, resulting in a spark and heat generation.













---



## GENERAL PRECAUTIONS

### WARNING

A pump is a pressure vessel with rotating parts that can be hazardous. Hazardous fluids may be contained by the pump including high temperature, flammable, acidic, caustic, explosive, and other risks. Operators and maintenance personnel must realize this and follow safety measures. Personal injuries will result if procedures outlined in this manual are not followed. ITT Goulds Pumps will not accept responsibility for physical injury, damage or delays caused by a failure to observe the instructions in this manual and the IOM provided with your equipment.

General Precautions		
WARNING		NEVER APPLY HEAT TO REMOVE IMPELLER. It may explode due to trapped liquid.
WARNING		NEVER use heat to disassemble pump due to risk of explosion from tapped liquid.
WARNING		NEVER operate pump without coupling guard correctly installed.
WARNING		NEVER run pump below recommended minimum flow when dry, or without prime.
WARNING		ALWAYS lock out power to the driver before performing pump maintenance.
WARNING		NEVER operate pump without safety devices installed.
WARNING		NEVER operate pump with discharge valve closed.
WARNING		NEVER operate pump with suction valve closed.
WARNING		DO NOT change service application without approval of an authorized ITT Goulds Pumps representative.
WARNING		<p><b>Safety Apparel:</b></p> <ul style="list-style-type: none"> <li>♦ Insulated work gloves when handling hot bearings or using bearing heater</li> <li>♦ Heavy work gloves when handling parts with sharp edges, especially impellers</li> <li>♦ Safety glasses (with side shields) for eye protection</li> <li>♦ Steel-toed shoes for foot protection when handling parts, heavy tools, etc.</li> <li>♦ Other personal protective equipment to protect against hazardous/toxic fluids</li> </ul>
WARNING		<p><b>Receiving:</b></p> <p>Assembled pumping units and their components are heavy. Failure to properly lift and support equipment can result in serious physical injury and/or equipment damage. Lift equipment only at specifically identified lifting points or as instructed in the current IOM. Current manuals are available at <a href="http://www.gouldspumps.com/literature_ioms.html">www.gouldspumps.com/literature_ioms.html</a> or from your local ITT Goulds Pumps sales representative. Note: Lifting devices (eyebolts, slings, spreaders, etc.) must be rated, selected, and used for the entire load being lifted.</p>
WARNING		<p><b>Alignment:</b></p> <p>Shaft alignment procedures must be followed to prevent catastrophic failure of drive components or unintended contact of rotating parts. Follow coupling manufacturer's coupling installation and operation procedures.</p>

<b>General Precautions</b>		
<b>WARNING</b>		Before beginning any alignment procedure, make sure driver power is locked out. Failure to lock out driver power will result in serious physical injury.
<b>CAUTION</b>		<b>Piping:</b> Never draw piping into place by forcing at the flanged connections of the pump. This may impose dangerous strains on the unit and cause misalignment between pump and driver. Pipe strain will adversely effect the operation of the pump resulting in physical injury and damage to the equipment.
<b>WARNING</b>		<b>Flanged Connections:</b> Use only fasteners of the proper size and material.
<b>WARNING</b>		Replace all corroded fasteners.
<b>WARNING</b>		Ensure all fasteners are properly tightened and there are no missing fasteners.
<b>WARNING</b>		<b>Startup and Operation:</b> When installing in a potentially explosive environment, please ensure that the motor is properly certified.
<b>WARNING</b>		Operating pump in reverse rotation may result in contact of metal parts, heat generation, and breach of containment.
<b>WARNING</b>		Lock out driver power to prevent accidental start-up and physical injury.
<b>WARNING</b>		The impeller clearance setting procedure must be followed. Improperly setting the clearance or not following any of the proper procedures can result in sparks, unexpected heat generation and equipment damage.
<b>WARNING</b>		If using a cartridge mechanical seal, the centering clips must be installed and set screws loosened prior to setting impeller clearance. Failure to do so could result in sparks, heat generation, and mechanical seal damage.
<b>WARNING</b>		The coupling used in an ATEX classified environment must be properly certified and must be constructed from a non-sparking material.
<b>WARNING</b>		Never operate a pump without coupling guard properly installed. Personal injury will occur if pump is run without coupling guard.
<b>WARNING</b>		Make sure to properly lubricate the bearings. Failure to do so may result in excess heat generation, sparks, and / or premature failure.
<b>CAUTION</b>		The mechanical seal used in an ATEX classified environment must be properly certified. Prior to start up, ensure all points of potential leakage of process fluid to the work environment are closed.
<b>CAUTION</b>		Never operate the pump without liquid supplied to mechanical seal. Running a mechanical seal dry, even for a few seconds, can cause seal damage and must be avoided. Physical injury can occur if mechanical seal fails.
<b>WARNING</b>		Never attempt to replace packing until the driver is properly locked out and the coupling spacer is removed.
<b>WARNING</b>		Dynamic seals are not allowed in an ATEX classified environment.
<b>WARNING</b>		DO NOT operate pump below minimum rated flows or with suction and/or discharge valve closed. These conditions may create an explosive hazard due to vaporization of pumpage and can quickly lead to pump failure and physical injury.

<b>General Precautions</b>		
<b>WARNING</b>		Ensure pump is isolated from system and pressure is relieved before disassembling pump, removing plugs, opening vent or drain valves, or disconnecting piping.
<b>WARNING</b>		<b>Shutdown, Disassembly, and Reassembly:</b> Pump components can be heavy. Proper methods of lifting must be employed to avoid physical injury and/or equipment damage. Steel toed shoes must be worn at all times.
<b>WARNING</b>		The pump may handle hazardous and/or toxic fluids. Observe proper decontamination procedures. Proper personal protective equipment should be worn. Precautions must be taken to prevent physical injury. Pumpage must be handled and disposed of in conformance with applicable environmental regulations.
<b>WARNING</b>		Operator must be aware of pumpage and safety precautions to prevent physical injury.
<b>WARNING</b>		Lock out driver power to prevent accidental startup and physical injury.
<b>CAUTION</b>		Allow all system and pump components to cool before handling them to prevent physical injury.
<b>CAUTION</b>		If pump is a Model NM3171, NM3196, 3198, 3298, V3298, SP3298, 4150, 4550, or 3107, there may be a risk of static electric discharge from plastic parts that are not properly grounded. If pumped fluid is non-conductive, pump should be drained and flushed with a conductive fluid under conditions that will not allow for a spark to be released to the atmosphere.
<b>WARNING</b>		Never apply heat to remove an impeller. The use of heat may cause an explosion due to trapped fluid, resulting in severe physical injury and property damage.
<b>CAUTION</b>		Wear heavy work gloves when handling impellers as sharp edges may cause physical injury.
<b>CAUTION</b>		Wear insulated gloves when using a bearing heater. Bearings will get hot and can cause physical injury.

## ATEX CONSIDERATIONS and INTENDED USE

Special care must be taken in potentially explosive environments to ensure that the equipment is properly maintained. This includes but is not limited to:

1. Monitoring the pump frame and liquid end temperature.
2. Maintaining proper bearing lubrication.
3. Ensuring that the pump is operated in the intended hydraulic range.

The ATEX conformance is only applicable when the pump unit is operated within its intended use. Operating, installing or maintaining the pump unit in any way that is not covered in the Instruction, Operation, and Maintenance manual (IOM) can cause serious personal injury or damage to the equipment. This includes any modification to the equipment or use of parts not provided by ITT Goulds Pumps. If there is any question regarding the intended use of the equipment, please contact an ITT Goulds representative before proceeding. Current IOMs are available at [www.gouldspumps.com/literature\\_ioms.html](http://www.gouldspumps.com/literature_ioms.html) or from your local ITT Goulds Pumps Sales representative.

All pumping unit (pump, seal, coupling, motor and pump accessories) certified for use in an ATEX classified environment, are identified by an ATEX tag secured to the pump or the baseplate on which it is mounted. A typical tag would look like this:



The CE and the Ex designate the ATEX compliance. The code directly below these symbols reads as follows:

- II = Group 2
- 2 = Category 2
- G/D = Gas and Dust present
- T4 = Temperature class, can be T1 to T6 (see Table 1)

<b>Code</b>	<b>Max permissible surface temperature °F (°C)</b>	<b>Max permissible liquid temperature °F (°C)</b>
T1	842 (450)	700 (372)
T2	572 (300)	530 (277)
T3	392 (200)	350 (177)
T4	275 (135)	235 (113)
T5	212 (100)	Option not available
T6	185 (85)	Option not available

The code classification marked on the equipment must be in accordance with the specified area where the equipment will be installed. If it is not, do not operate the equipment and contact your ITT Goulds Pumps sales representative before proceeding.



# PARTS



The use of genuine Goulds parts will provide the safest and most reliable operation of your pump. ITT Goulds Pumps ISO certification and quality control procedures ensure the parts are manufactured to the highest quality and safety levels.

Please contact your local Goulds representative for details on genuine Goulds parts.

---





# INSTALLATION AND OPERATING INSTRUCTIONS

INST. NO. W  
PAGE NO. 1

## Section I General Pump Instructions

This section is a general installation and operating instruction for most Morris pumps. Specific text and illustrations are included in Section II. The purpose of Section I is to explain those conditions common to different types of pumps.

To insure pump performance and operating life, proper installation and reasonable maintenance are required. The following instructions are a guide for installation and maintenance personnel and the pump operator.

### A. PREPARATION FOR SHIPMENT

Morris pumps are prepared at the factory for shipment under covered conditions. They are protected for transport and short term covered storage. Unless otherwise specified, it is assumed the pump will be installed upon delivery. Additional protection can be provided by request.

### B. INSTALLATION

#### 1. Location of Unit

The pump should be located in a clean, dry area free from flooding. The area should provide adequate space for maintenance and repair, considering complete disassembly and handling of equipment. The unit should be positioned to provide the most efficient pipeline system.

#### 2. Piping

Short, direct suction and discharge pipelines and a minimum of elbows and fittings result in the least amount of pipe friction.

##### Suction Piping

- Excessive friction losses will cause cavitation.
- Must be kept free of air leaks, particularly in long lines or conditions of high suction lift.
- Flow regulating valves must not be located on suction side of the pump.

##### Discharge Piping

- Excessive friction losses result in insufficient head.
- A check valve should be located in the discharge line to protect the pump from reverse flow and excessive pressure.

##### Piping Support

The pumps are not designed to carry loads imposed by the weight of the pipeline. Suction and discharge piping must be supported near

the pump, unless otherwise specified. Pumps and subbases can be designed to carry loads due to thermal expansion.

### 3. Foundation

The foundation must be a permanent, rigid support for the subbase or floorplate. It should be an industrially accepted design capable of absorbing excessive vibration. Foundations are typically concrete with anchor bolts cast in to secure the pump.

An anchor bolt assembly consists of a bolt and washer with a sleeve  $2\frac{1}{2}$  times the diameter of the bolt. When the assembly is cast in concrete, the washer prevents the sleeve and bolt from being pulled. The sleeve I.D. provides an adjustment allowance around the bolt. A lug is generally welded on the bolt to prevent rotation when tightening. Anchor bolts should be located in the concrete by a template dimensioned from the pump installation drawing. The top of the sleeve should be temporarily sealed with waste material to prevent concrete from entering during the concrete pouring operation.

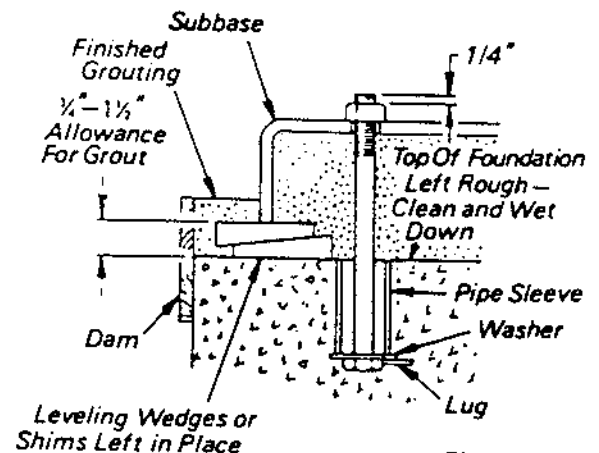

Fig W1  
Typical Anchor Bolt

### 4. Installing Pump on Foundation

If subbases or floorplates were directly anchored to poured concrete foundations, surface irregularities would cause distortion. Rectangular metal blocks and shims, or metal wedges having a small taper, are placed beside each anchor bolt to level the subbase or floorplate (see Fig. W2 and Fig. W3 on following page). The anchor bolts are then drawn tight enough to maintain position and level.



To secure the shims in place and provide a level surface for the base or plate, grout is poured over the concrete foundation. A  $\frac{3}{4}$ " to 1- $\frac{1}{2}$ " grout allowance is recommended. When subbases have cavities, grout holes are provided to fill all spaces. After the grout has hardened, permanently tighten the anchor bolts.

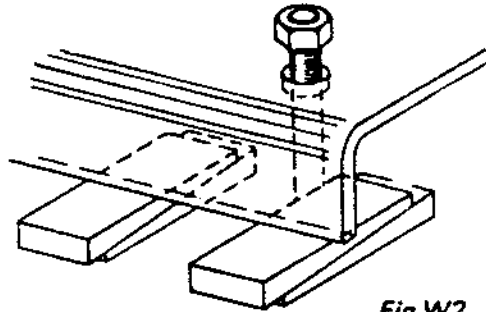

Fig W2  
Leveling With Wedges

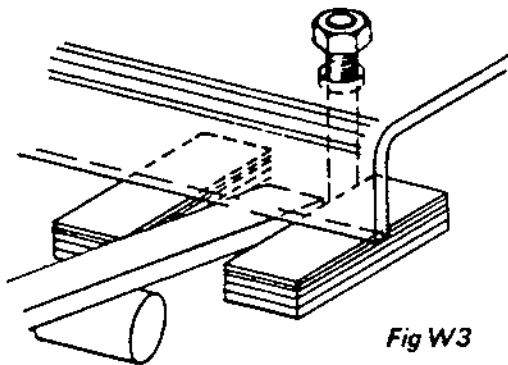
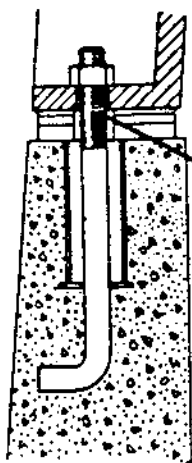

Fig W3  
Leveling With Blocks  
and Shims

When the grout has hardened and the anchor bolts are permanently secured, recheck level.  
NOTE: On large subbases/floorplates, shimming is recommended to be at 24" spacing.



TYPICAL

**DO NOT Use Nut Here  
To Level Pump.**

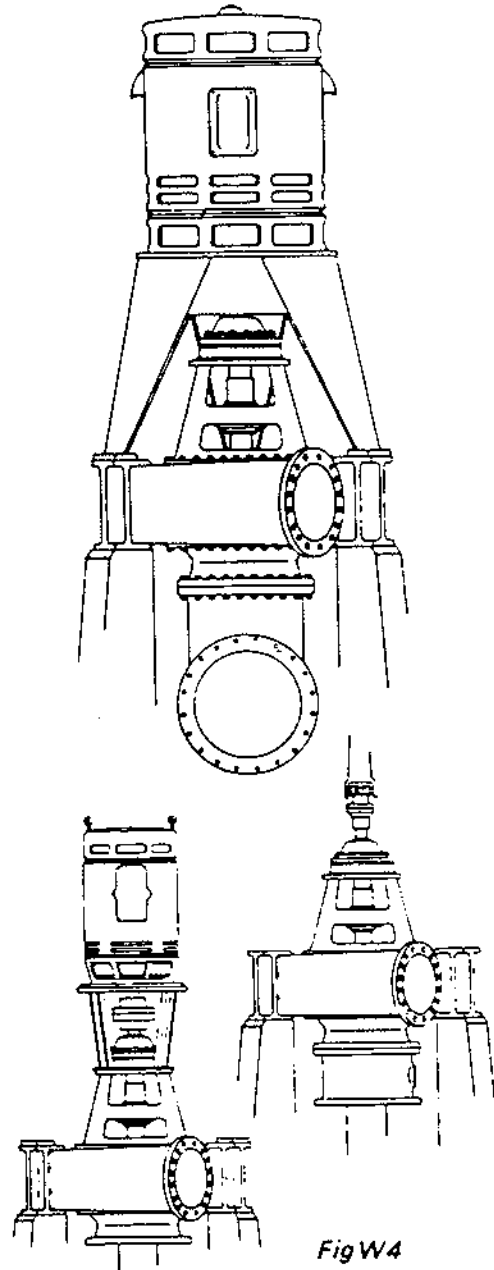

Fig W4

Dry pit vertical pumps are casing mounted on either concrete piers or a casing support. To level the casing, shim between the casing feet and the piers. If a casing support is used, shim between support feet and foundation. Maintain level and position with anchor bolts. Do not fully tighten anchor bolts. Install a grout dam around the foot and grout shims in place.



# INSTALLATION AND OPERATING INSTRUCTIONS

INST. NO. W  
PAGE NO. 3

Wet pit vertical pumps are supported on the perimeter of the floorplate. Level by shims beside each anchor bolt and grout as described in "Installing Pump on Foundation".

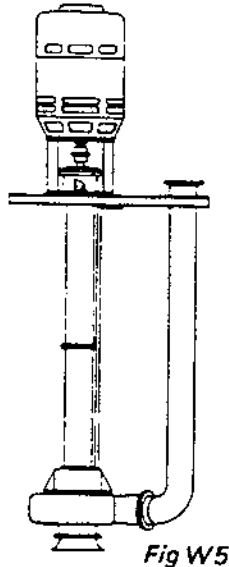

Fig W5

Subbase mounted horizontal pumps may be shipped with or without drivers and gears. Be sure pump and drivers are uncoupled before installation. Level by shimming beside each anchor bolt and grout as described in "Installing Pump on Foundation".

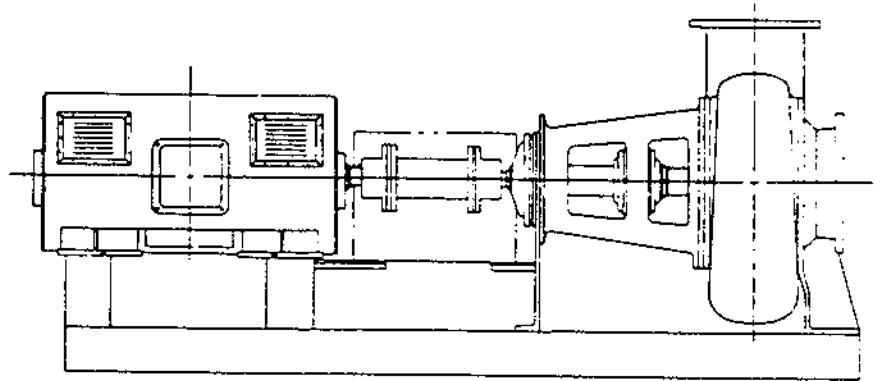

Fig W6

## C. PUMP-DRIVER ALIGNMENT

### 1. Shaft Alignment of Horizontal Pump & Driver

Pumps and drivers that are received from the factory with both machines mounted on a common subbase were accurately aligned before shipment. Because all subbases are, to some extent, flexible, factory alignment may be altered during shipment and handling. After the subbase has been leveled, grouted, and secured, check the alignment. Alignment should be rechecked after the pump is fully installed and before startup. Refer to the "Alignment Procedure".

- a. On certain large units, limited end-float couplings are used, and the instruction book furnished with such units should be consulted for the special alignment instructions that apply to such couplings.
- b. Disconnect coupling halves before proceeding with alignment. Check for angular and parallel alignment in the next section, "Alignment Procedure". The faces and outside diameters of the coupling halves must be square and concentric with the bores. If this condition does not exist, the "Alternate Method" of alignment described on page 4 is recommended.

### 2. Alignment Procedure

A check for angular alignment is made by inserting the taper gauge or feelers at four points between the coupling faces and comparing the distance between the faces at four points spaced around the coupling. The unit will be in angular alignment when the measurements show that the coupling faces are the same distance apart at all points (Fig. W7).

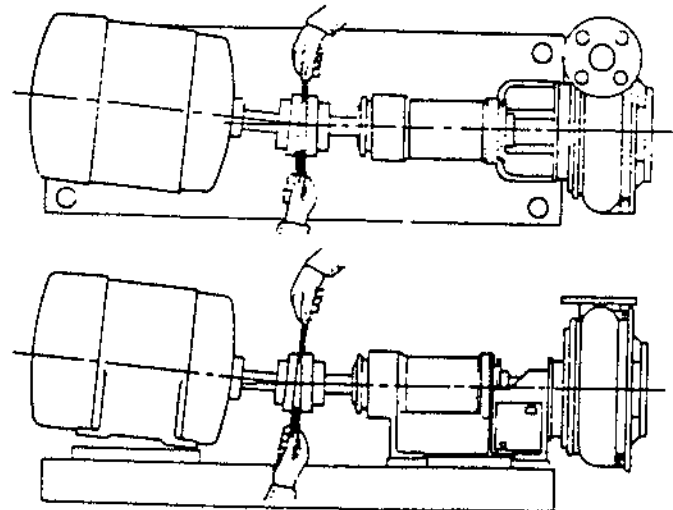

CHECKING ANGULAR ALIGNMENT

Fig. W7

# INSTALLATION AND OPERATING INSTRUCTIONS



A check for parallel alignment is made by placing a straight edge across both coupling rims at the top, bottom, and at both sides. The unit will be in parallel alignment when the straight edge rests evenly on the coupling rim at all positions. Allowance may be necessary for temperature changes and for coupling halves that are not of the same outside diameter.

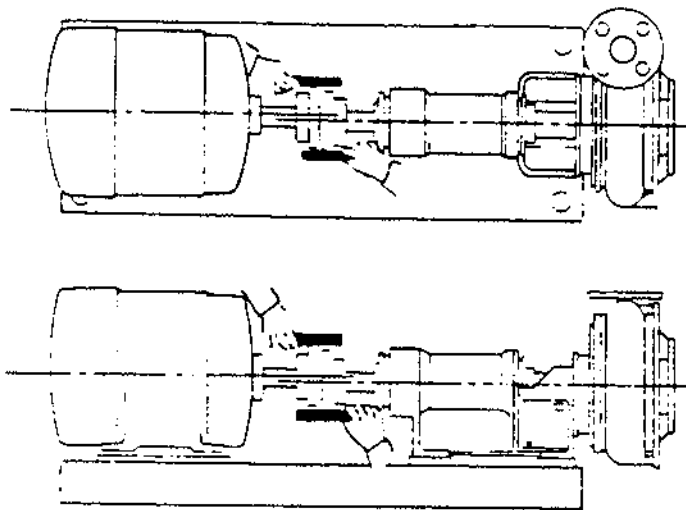

CHECKING PARALLEL ALIGNMENT

Fig. W8

**NOTE:** Care must be taken to have the straight edge parallel to the axis of the shafts (Fig. W8).

Angular and parallel misalignment are corrected by means of shims under the motor mounting feet. After each change, it is necessary to recheck the alignment of the coupling halves. Adjustment in one direction may disturb adjustments already made in another direction. It should not be necessary to adjust the shims under the pump.

The permissible amount of misalignment will vary with the type of pump and driver. The manufacturer's recommendations should be obtained and followed.

When the driver is to be mounted on the subbase in the field, it is necessary to place the subbase with pump on the foundation to level the pump shaft, to check the coupling faces, the suction and discharge flanges for horizontal or vertical position, and to make any necessary corrective adjustments.

When the units are lined up cold, it may be necessary to make an allowance for the vertical rise

of the driver and/or pump caused by heating. Morris Pumps' recommendations should be obtained and followed.

### 3. Alternate Method of Alignment

An approved method for putting the coupling halves in final accurate alignment is by the use of a dial indicator. Check alignment by straight edge, taper gauge or feelers as accurately as possible by procedure indicated above.

Bolt the indicator to the pump half of the coupling, with the indicator button resting on the other half coupling periphery, set the dial to zero, and chalk mark the coupling half at the point where the button rests. For any check, top, bottom, or sides, rotate both shafts by the same amount; i.e., all readings on the dial must be made with button on the chalk mark.

The dial readings will indicate whether the driver has to be raised or lowered or moved to either side. After each movement, check to see that coupling faces remain parallel to one another.

With this method, accurate alignment of shaft centers can be obtained even where faces or outside diameters of the coupling halves are not square or concentric with the bores, provided all measurements for angular alignment are made between the same two points on the faces, and all measurements for parallel alignment are made between the same two points on the outside diameters. Gross deviations in squareness or concentricity, however, may cause problems due to coupling unbalance or abnormal coupling wear and may need to be corrected for reasons other than accomplishment of shaft alignment.

### 4. Alignment of Gear Type Couplings

Gear type couplings are aligned in the same manner as outlined above. However, the coupling covers must be moved back out of the way and measurements made on the coupling hubs as shown on Fig. W9.

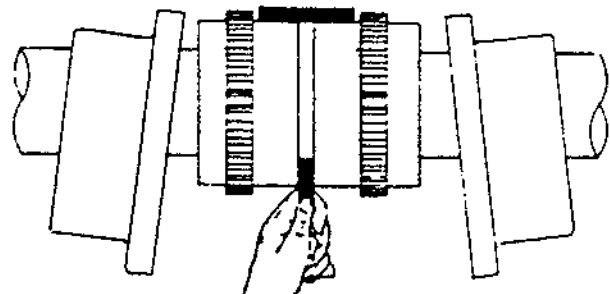

GEAR COUPLING ALIGNMENT

Fig. W9



# INSTALLATION AND OPERATING INSTRUCTIONS

INST.NO. W

PAGE.NO. 5

## 5. Alignment of Spacer Type Couplings

Where a spacer type coupling is used between the pump and driver, it is not possible to align the couplings of the pump and driver as previously described. To align units with a floating coupling, remove the spacer between the pump and driver. Make a bracket, as shown in Fig. W10, which can be fastened to one of the coupling halves and which is long enough to reach the other coupling half. Fasten this bracket to one coupling half and a dial-type indicator to the bracket arm so that the indicator is in contact with the rim of the other coupling half as shown at A, Fig. W10. Revolve one coupling half by hand so that the indicator moves around the other coupling half.

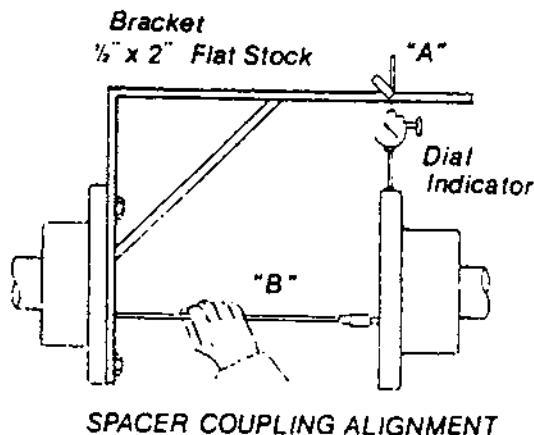

Fig.W10

After alignment on the coupling rim has been obtained, change the indicator so it bears against the face of the same coupling half and make any necessary adjustments. If the shafts have end play, it is preferable to make this check of face alignment by using inside micrometers as shown at B, Fig.W10.

Change the bracket, fastening it to the other coupling half, and use the indicator, as described above, against the face and rim of opposite coupling half.

After final alignment is obtained, insert the spacer and bolt the coupling halves.

## 6. Shaft Alignment of Vertical Pump & Driver

Check for parallel alignment by placing a straight edge across both coupling rims at four points. The unit will be in parallel alignment when the straight edge rests evenly on the coupling rim at all positions (Fig. W11).

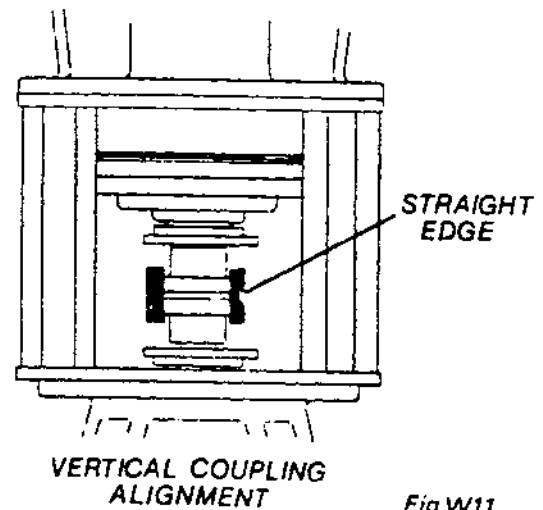

Fig.W11

(Refer to "Alternate Method of Alignment" under Horizontal Section).

## 7. Factors That May Disturb Alignment

The unit should be checked periodically for alignment. If the unit does not stay in line after being properly installed, the following are possible causes:

- (1) Settling, seasoning or spring of the foundation.
- (2) Wear of the bearings.
- (3) Pipe strains distorting or shifting the machine.
- (4) Springing of the base plate by heat from an adjacent steam pipe or from a steam turbine.
- (5) Shifting of the building structure due to variable loading or other causes.
- (6) Loose nuts or bolts on the pump or driver assembly.

## D. STUFFING BOXES

In the conventional stuffing box, mechanical seals and packing seal between the stationary and rotating components of the pump. Generally a clear liquid such as water is forced through the stuffing box to lubricate the sealing elements. The lubricating liquid pressure must exceed the pressure of the pumpage at the stuffing box. For end suction pumps, lubricating liquid pressure should be 10-15 PSIG higher than the discharge pressure. For side and double suction pumps, lubricating liquid pressure should be 10-15 PSIG higher than the suction pressure.

NOTE: TO DETERMINE SUCTION OR DISCHARGE PRESSURE, USE GAUGE PRESSURE ONLY.



The piping supplying the lubrication liquid should be fitted tightly to prevent air from entering. On suction lifts, a small quantity of air entering the pump at this point may result in loss of suction.

Lubrication liquid pressure is controlled by a valve on the outlet piping. Since the liquid leaking from the stuffing box should be clear, control of the packing lubricant will vary with the condition of the packing. Increase pressure within the stuffing box by closing outlet valve. Adjustments should be slow and consistent with the run-in procedure for new packing.

The lubricating liquid must be clean, free of grit and acid. Shaft sleeve scoring, packing destruction, and mechanical seal face damage will result from contaminated lubricant.

## 1. Packing

Original equipment packing is a suitable grade for the service intended. To replace original packing, contact local packing suppliers.

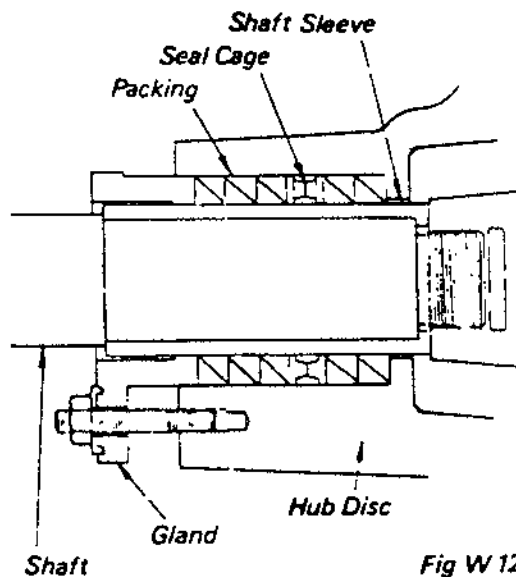

Fig W 12

Typical Stuffing Box

Refer to Bill of Material and Assembly Drawing for specific packing size and configuration.

## 2. Packing Procedure

- Stuffing box and shaft sleeve must be clean and free of grit.
- Form packing over shaft or mandrel of same diameter. Carefully cut to packing length. Discard rings cut too short.
- Pre-form each ring by coiling 1-½ turns.
- To install packing rings, do not pull straight. Expand the coil as a coil spring. (See Fig. W13.)

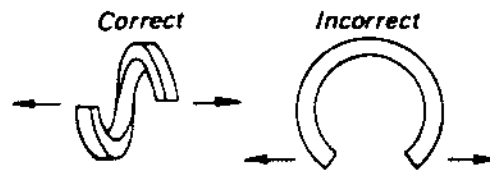

Stuffing Box Packing

Fig W 13

- Expand first coil as shown and insert into stuffing box. Tamp packing to stuffing box shoulder firmly with the gland. Note where the cut is positioned.
- Install second and third coils as required by assembly drawing, staggering the cut 90°-120°.
- Insert seal cage (lantern ring) into stuffing box, carefully noting its proper position on assembly drawing. Failure to properly locate seal cage will result in insufficient packing lubrication. Packing and shaft sleeve damage will occur.
- After packing and seal cage are properly installed, insert gland into stuffing box. Tighten gland nuts finger-tight only. Shaft should turn freely.
- Follow pump start-up procedure. Turn on stuffing box lubricating liquid and start pump.
- A significant amount of lubricating liquid should leak from gland side of stuffing box. Operate pump for at least 15 minutes before tightening gland nuts. Make small, even gland nut adjustments to reduce leakage. Allow adequate run-in time between adjustments. Acceptable leakage is 30-50 drops per minute.

**NOTE:** Do not overtighten gland nuts. Packing may set permanently and require removal. Overtightened packing causes excessive friction between packing and sleeve, and will result in damaged components. A noticeable temperature increase in stuffing box would indicate insufficient lubrication.

- Periodic maintenance is absolutely required for all packed pumps.

Normal shaft run-out should be under .005" to avoid pounding of stuffing box packing. With excessive shaft run-out, shaft straightening or replacement is necessary.

## 3. Mechanical Seals

Most mechanical seals are installed and adjusted at the factory. Due to size and design, some installed mechanical seals are supplied with shipping retainers. Shipping retainers hold the sealing faces





# INSTALLATION AND OPERATING INSTRUCTIONS

INST. NO. W

PAGE NO. 7

apart to avoid damage during transport. Shipping retainers must be removed before shaft is to be rotated. Pumps with retained seal faces will be specially marked and instructions from the seal manufacturer for retainer removal will be provided.

Mechanical seals have a stationary and a rotating sealing face. Commonly, these sealing rings are of carbon and ceramic material, brittle in nature, and easily damaged. As the sealing rings seat with the operation of the pump, a compatible wear pattern develops between the mating surfaces. To disassemble the mechanical seal after the wear pattern is established would necessitate the replacement of the rotating and stationary sealing elements. Do not replace only one component.

To insure the life and sealing characteristics of the mechanical seal, lubricating liquid must be circulated through the stuffing box. Clear, grit free liquid is necessary.

Special seal information and replacement seal elements should be provided by the seal manufacturer. Morris strongly recommends the stocking of replacement sealing elements.

**CAUTION: DO NOT MAKE SHAFT ADJUSTMENTS ON MECHANICAL SEAL INSTALLATIONS, WITHOUT CONSULTING SEAL INSTRUCTIONS AND PUMP ASSEMBLY DRAWING.**

## E. PUMP START-UP

1. Bearing Lubrication: Bearing must have adequate lubrication. Engage external lubrication system. Consult "BEARING SECTION" of these instructions for specific information.
2. Shaft Rotation: The pump shaft must turn without any binding or rubbing. By manually turning the rotating element, only the uniform frictional drag of the bearings and the stuffing box should be sensed.
3. Correct Rotation of the Driver: The direction of rotation of the driver must be checked before it can be coupled with the pump. The direction of rotation of the pumps is indicated

in a prominent location. For pumps with impellers threaded on the shaft, reverse rotation would back the shaft from the impeller thread. Considerable damage may occur.

4. Lubricating Lines to Stuffing Box: Lubricating liquid must be flowing to the stuffing box before the pump is started. Both mechanical seals and packing require lubrication for continuous service.
5. Priming: The pump must be completely primed before operation.

## F. WATER HAMMER

Water hammer is a high pressure surge within a closed pipe system, created by rapid change in the flow rate. Changes in the flow rate occur when there are sudden changes in pump speed. The most common cause is the sudden opening or closing of a valve or flow control device. Extensive damage to the pump and pipeline is a result of water hammer.

## G. FREEZING

If the pump is exposed to below freezing temperatures, the liquid should be drained during idle periods.

## H. LOCATING PROBLEMS

1. Conditions Leading to Insufficient or No Discharge
  - a. Insufficient speed.
  - b. Excessive discharge head.
  - c. Insufficient NPSH.
  - d. Worn pump components.
  - e. Incorrect direction of rotation.
  - f. Incomplete pump priming.
  - g. Impeller or discharge pipe clogged.
  - h. Pumpage viscosity too high.
2. Conditions Leading to Excessive Power Consumption
  - a. Excessive speed.
  - b. Pump operating at high horsepower area of the pump curve (off design point).
  - c. Mechanical binding or rubbing of rotating element.
  - d. Pumpage specific gravity and/or viscosity too high.

## WARNING !

THIS UNIT MUST NEVER BE USED WITHOUT PRIOR INSTALLATION OF THE SAFETY GUARDS FOR ROTATING PARTS AS PRESCRIBED BY O. S. H. A.

OPERATION OF THIS PUMP WITH BOTH SUCTION AND DISCHARGE VALVES CLOSED FOR EVEN BRIEF PERIODS OF TIME IS AN UNACCEPTABLE AND DANGEROUS PRACTICE. IT CAN RAPIDLY LEAD TO A VIOLENT PUMP FAILURE.

**INSTALLATION AND  
OPERATING INSTRUCTIONS****-- SPECIAL NOTICE --**

When ordering spare parts for this pump, always refer to the pump serial number and part number. This will avoid delays in identification. In certain cases where pumps are furnished with special metals, deliveries are quite lengthy. It is therefore advisable to anticipate your requirements several months in advance so that possible long deliveries will not handicap your operation.



# INSTALLATION AND OPERATING INSTRUCTIONS

INST. NO. X-152

PAGE NO. 1

2/11/80

## TYPE "HM" BEARING ASSEMBLY

### GENERAL

The "HM" bearing assembly is used for horizontal and vertical pumps. The inboard or lower bearing is an angular contact ball bearing with high thrust capacity and the outboard or top bearing is a high radial capacity ball bearing. Grease is the standard lubricant, but horizontal bearing assemblies can be furnished for oil lubrication. The "HM" bearing assembly has a split housing for ease of assembly and disassembly.

### BEARING LUBRICATION AND CARE

NOTE: The shaft seals (#1900) at each bearing should be oiled with a few drops of #20 or #30 oil before the pump is started to insure lubrication of the seal lip while the seal is "running in".

### GREASE LUBRICATION

When the pump is furnished with grease lubrication, a quality bearing grease equivalent to Mobilux #2 should be used to insure long bearing life.

Grease lubricated pumps are assembled with the bearings hand-packed with grease at the factory and should be allowed to run for eight hours before any grease is added. The suggested interval for adding a small amount of grease is five hundred (500) hours; however, the operating conditions and experience of the customer with other equipment can be used to establish a more suitable lubrication schedule for the particular application.

Adding excessive amounts of grease will increase the bearing temperature and shorten the lubricating life of the grease.

### OIL LUBRICATION

When the pump is furnished with oil lubrication, a high quality bearing oil should be used to insure long bearing life. PUMPS FURNISHED FOR OIL LUBRICATION ARE SHIPPED WITHOUT OIL. ADD OIL UNTIL THE LEVEL IS UP TO THE OIL LEVEL LINE BEFORE THE UNIT IS STARTED. If too much oil is added, there will be excessive heat generated in the bearings and there may be leakage from the shaft seals. We recommend a commercial oil such as Mobil D.T.E. oil, B.B., or equal. However, a

# INSTALLATION AND OPERATING INSTRUCTIONS



good grade of non-detergent oil of #30 wgt. is usually satisfactory. The oil should have a minimum viscosity of 100 Sec. Saybolt at the normal operating temperature.

For normal operating conditions, change the oil at least once a year and thoroughly flush the bearings. If the bearing assembly is exposed to dirty or moist conditions, the oil should be changed more often.

## INSTALLING A BEARING

Long bearing life is quite dependent on careful handling of the bearing when it is out of the housing and during the installation procedure. Dirt and rough handling are prime enemies of precision bearings. Bearings should be pressed, not "hammered" into place. If heat is used to facilitate the installation, a hot oil bath is the best method. Bearings for grease lubrication should be hand-packed with grease to insure adequate lubrication at startup.

## NORMAL BEARING TEMPERATURE

The running temperature for a bearing assembly depends on many factors such as speed, bearing loads, ambient air temperature, and condition of bearings. Temperatures higher than the human hand can tolerate are very satisfactory for good bearing operation and should not cause any alarm.

For a given speed and loading, the bearing housing temperature will stabilize at some temperature, usually below 200° F., which will be the normal temperature for that installation. Higher temperatures than this normal temperature, without any change in speed or loading, can mean a lubrication difficulty or the approach of a bearing failure.

## TO DISASSEMBLE THE BEARING ASSEMBLY

1. Disassemble the liquid end in accordance with the instructions for that section.
2. Remove the cap screws which fasten the retainers (#804 & #904) to the bearing housing and pull the retainers off the shaft. Retainer (#804) will push the slinger (#2430) off the shaft with it.
3. Tap the taper pins out and then remove the cap screws which hold the two housing halves together. Separate the two halves and lift the shaft, with bearings, out.
4. Press the bearings off the shaft by pushing against the inner race.



## INSTALLATION AND OPERATING INSTRUCTIONS

INST. NO. X-152  
PAGE NO. 3

### TO ASSEMBLE THE BEARING ASSEMBLY

1. Slide the retaining rings (#1400) onto the center of the shaft so that they will be between the bearings.
2. Press the bearings on the shaft. Make sure the thrust bearing (#800) is properly orientated. The thrust side of the outer race must face the retainer.
3. Carefully lower the shaft, with bearings and retaining rings, into the half of the housing that has the small end of the taper pins. Make sure the retaining rings enter the grooves in the housing.
4. Lower the other half of the housing into position. Use the taper pins as a guide and make sure the retaining rings properly enter the housing grooves. Capscrew the two housing halves together.
5. Slide the thrust bearing retainer (#804) into position and secure with cap screws.
6. Slide the radial bearing retainer (#904) into position. Make sure the thrust bearing is pushed against the other retainer and measure the gap between the retainer (#904) and the housing. See note "N".
7. Remove the retainer and install the necessary shims to give a thickness .005" - .008" greater than the measured gap. This will keep the retainers from axially preloading the thrust bearing against the radial bearing. Secure the retainer with cap screws.
8. Slide the slinger (#2430) into position close to the retainer, but with sufficient gap to prevent it from rubbing.





# INSTALLATION AND OPERATING INSTRUCTIONS

INST. NO. Y-152

PAGE NO. 1

2/11/80

## HS PUMP LIQUID END

### GENERAL

The impeller of the HS pump is recessed in a circular opening at the back of the casing. The uniform running clearance between the impeller and the casing keeps a uniform pressure around the outside of the impeller, and the resulting hydraulic forces on the impeller are low compared to the conventional centrifugal pump.

The bearing loads and deflection through the stuffing box are reduced with the HS configuration. The impeller is fitted with back vanes to reduce the axial pressure unbalance and the resulting loads on the thrust bearings.

The HS pump is designed to pass any solid which can enter through the suction opening, provided the solid is not significantly longer than it is wide. Most of the solids do not flow through the impeller passageways.

### CLEARANCE ADJUSTMENT

The HS impeller should have approximately 1/8" running clearance for the back vanes on the stuffing box side of the impeller. The standard HS and VHS bearing assemblies are machined to provide the proper clearance without any adjustment features. Other bearing assemblies which may be furnished for special pumps have provisions for axial clearance adjustment. The bearing section of the operating instructions will explain any axial adjustments used.

### TO DISASSEMBLE THE LIQUID END

1. Drain all liquid from the pipe line. Remove the discharge flange bolts and the suction pipe.
2. Remove the cap screws which fasten the casing (#100) to the hub (#400). Carefully slide the casing away, making sure it does not drop down onto the impeller after it has cleared the fit in the hub disc flange.
3. Remove the impeller:
  - (a) The standard impeller has an impeller nut and drive key as illustrated in this section. Unscrew the impeller nut (right hand pump will have a right hand impeller nut) and

## INSTALLATION AND OPERATING INSTRUCTIONS



then carefully pull the impeller off the end of the shaft.

- (b) When specified by the customer, a screw-on impeller will be furnished. The screw-on impeller is removed by clamping the shaft and turning the impeller in the direction of normal rotation when pumping.
4. Remove the cap screws which fasten the hub disc (#400) to the bearing housing (#720)[horizontal assembly] or to the pipe column (#1600) [vertical assembly]. Carefully slide the hub disc from the end of the shaft (#600).

CAUTION: SOME HS PUMPS UTILIZE THE SAME CAP SCREWS TO SECURE THE CASING AND HUB DISC. IN THIS CASE, CLAMP THE HUB DISC IN POSITION WHILE REMOVING THE CASING. THEN THE HUB DISC MAY BE CAREFULLY SLID FROM THE SHAFT.

5. The sleeve (#619) may be pulled from the shaft (#600). If the stuffing box is packed remove gland (#507), seal cage (#523) and packing (#506).

### TO ASSEMBLE THE LIQUID END

1. The shaft sleeve (#619) must be clean and free of burrs. Slide the sleeve onto the shaft until it butts against the shaft shoulder.
2. Slide the hub disc (#400) into position over the shaft sleeve against the bearing housing. Secure in place with cap screws.
3. Install the impeller:
  - (a) Standard key drive: Make sure O-ring (#2700) is in place on the impeller hub and the key (#611) is in place on the shaft. Push the impeller into position and tighten on the impeller nut without the second O-ring (#2700). Remove the impeller nut, install the second O-ring and retighten the impeller nut.
  - (b) Screw-on impeller: Install the impeller gasket (#8100). Carefully engage the impeller thread on the shaft and then turn the impeller until the connection is tight.
4. Install gasket (#8101) on the casing and carefully lift the casing into position against the hub disc. Secure with cap screws.
5. Install the necessary packing, seal cage and gland in the stuffing box, but do not tighten the gland more than slightly snug until the pump has been run.



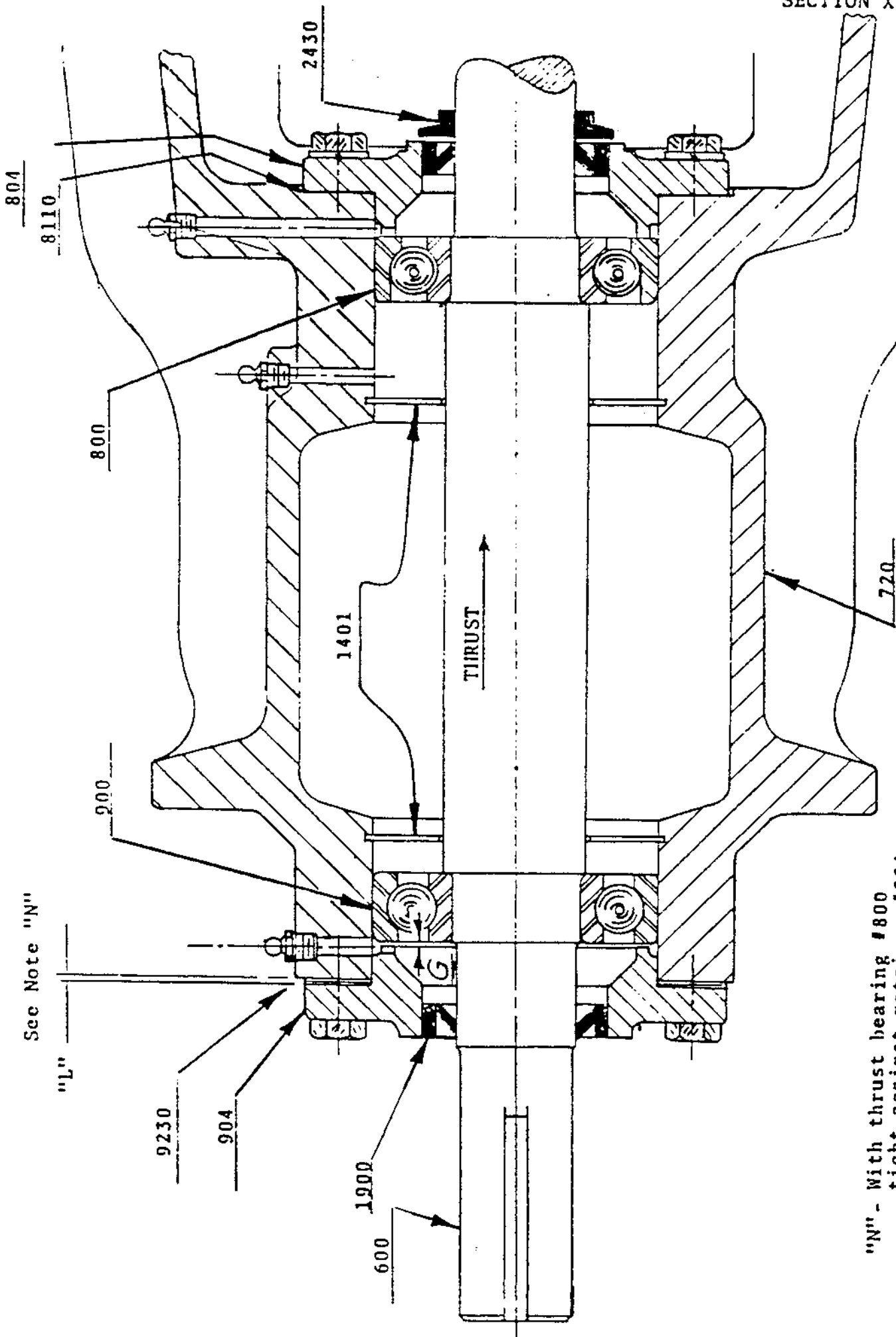

"N" - With thrust bearing #800 tight against retainer #804 measure "L" and install necessary shims to make .005" to .008" gap at "G"

TYPE "IM" BEARING ASSEMBLY  
(Vertical shown here)





Goulds Pumps

---

